



KEGEL



YOUR LANES | OUR PASSION

Lane Machines



Affordable Quality

The Crossfire is a compact, durable and highly functional lane machine at an extremely affordable price. This wick combination lane machine allows small centers to experience high quality lane maintenance only Kegel can deliver.

Features:

- ✔ Cleans and conditions the lane in about 80 seconds
- ✔ On-board keypad for simple machine programming
- ✔ 6 High-Flow Wick Pads (upgradeable)
- ✔ 12 Lane Conditioner Capacity (upgradeable)
- ✔ 32 Lane Cleaner Capacity
- ✔ 3 Drive Speeds for enhanced pattern taper
- ✔ Compact Design

Machine Weight : 275 lbs. | 124.7 Kg

Part Number:

Crossfire - 6 PAD MODEL B
17-5200 (115V/60 Hz) 6 PAD/CAM MACHINE
17-5250 (230V/50 Hz) 6 PAD/CAM MACHINE

Optional Upgrade Kit

Increase to 8 Wick Pads and Conditioner Capacity to 60 lanes
158-8241 - CROSSFIRE UPGRADE KIT - 115V
158-8241E - CROSSFIRE UPGRADE KIT - 230V



Innovation is the Key

The Kustodian PLUS sets a high benchmark for the Kustodian family of lane machines. It's equipped with Sanction Technology, a fluid metering oil system that gives you the ability to measure the exact volume of oil "before" you condition your lanes. Plus, the cleaning system features a patented sprayless system delivering the industry's cleanest lanes.

Features:

- ✔ Transfer Brush Conditioner system provides consistency with little maintenance
- ✔ Cushion roller wrap increases footprint on the lane to enhance cleaning performance
- ✔ Clean and Condition the lane in less than 90 seconds
- ✔ Condition only, clean only, and simultaneous modes
- ✔ 6 Drive Speeds for smooth lengthwise taper
- ✔ Large recovery tank can hold 50+ lanes of waste before emptying
- ✔ Cleaning cloth waste roll is located on top for easy removal
- ✔ KOSI Software is included to make pattern adjustments easy

Machine Weight : 302 lbs | 137 kg

Part Number:

17-5100 (115V/60 Hz) MODEL B
17-5150 (230V/50 Hz) MODEL B

Lane Machine Assist

Physical Properties:

- ✔ Color - Black (Custom colors are available by calling Kegel)
- ✔ Dimensions: Width: 60" | Height: 8" | Depth: 8"
- ✔ Lifting Capacity: Any Lane Machine (when mounted properly)
- ✔ Packaging: Assembled and ready to mount

Part Number: 154-8510 (Must be installed by a qualified contractor.)

One person can quickly and easily raise and lower their lane machine safely.





Cut the Cord

The Kustodian ION is battery powered so you don't need to hassle with the cord during use. While it cleans and conditions the lane, you have more time to do other things.

Features:

- ✔ All of the Kustodian Plus features
- ✔ Battery powered for hassle-free operation
- ✔ Dry-cell batteries can last up to 40 or 60 lanes per charge *
- ✔ Recharge as many as 400 times before battery replacement with proper maintenance
- ✔ Optional Battery Pack (provides up to an extra 25 lanes)

* For optimal charging, battery size is determined by the number of lanes in your center.

Machine Weight: ION MODEL B - 359 lbs | 162.8 kg

Part Number:

- 17-5400 (115V/60 Hz) MODEL B
- 17-5450 (230V/50 Hz) MODEL B



- ✔ All of the Kustodian ION Features
- ✔ Easy to use full color "Touchscreen Interface"
- ✔ 30 Lane Patterns in memory
- ✔ Change microliter per board setting with the touch of a button
- ✔ External Charger Assembly that allows for operation with power cord

- 17-5400D (115V/60 Hz) MODEL D (SPORT EDITION)
- 17-5450D (230V/50 Hz) MODEL D (SPORT EDITION)

Machine Weight - 382 lbs | 173.3 kg

BOTH ION MODELS CAN OPERATE WITH INCLUDED POWER CORD

Walk This Way

The Kustodian WALKER literally "does the lanes" for you. Just select the pattern you want, set it on the lane, and press the button. The machine springs to life cleaning and conditioning your whole center! With no cord to watch and no more moving the machine from lane-to-lane, you now have the freedom you want with the quality and consistency you need.

Features:

- ✔ All of the Kustodian ION Sport Edition features *
- ✔ Dry-cell batteries can last up to 60 lanes per charge
- ✔ Zero Turn Radius for easy movement from lane-to-lane
- ✔ Lane whiskers auto-align the machine for each lane
- ✔ Easy to use full color "Touchscreen Interface"
- ✔ 30 Lane Patterns in memory
- ✔ Battery saving auto-shutdown if not in use for 15 minutes
- ✔ Adjustable guide rollers to consistently center the machine on any lane or gutter track
- ✔ Battery Back-up included (provides up to an extra 20 lanes)
- ✔ Kegel Online Support Interface - KOSI™ Software

* Kustodian Walker includes Battery back-up and does not require power cord to operate.

Machine Weight - 425 lbs | 192.8 kg

Part Number:

- 17-5500D (115V/60 Hz) MODEL D (SPORT EDITION)
- 17-5550D (230V/50 Hz) MODEL D (SPORT EDITION)



Conditioners

For Use in Sanction and Wick-Pad Technology

NAVIGATE™ LANE CONDITIONER



Physical Properties:

- ✘ Viscosity - 29.6 cps.
- ✘ Surface Tension - 26.3 dynes/cm. (F/L)
- ✘ Shipping Weight - 40 lbs.
- ✘ Packaging: 1.25 gallon containers for easy use
(4 containers per case = 5 gallons)

Part Number: 156-8125

PRODIGY® LANE CONDITIONER



Physical Properties:

- ✘ Viscosity - 29.7 cps.
- ✘ Surface Tension - 27 dynes/cm. (F/L)
- ✘ Shipping Weight - 40 lbs.
- ✘ Packaging: 1.25 gallon containers for easy use
(4 containers per case = 5 gallons)

Part Number: 156-8095

Wick-Pad Technology



Physical Properties:

- ✘ Viscosity - 23 cps.
- ✘ Surface Tension - 28.1 dynes/cm. (F/L)
- ✘ Shipping Weight - 40 lbs.
- ✘ Packaging: 1.25 gallon containers for easy use
(4 containers per case = 5 gallons)

Part Number: 156-8105

INFINITY™ LANE CONDITIONER



Physical Properties:

- ✘ Viscosity - 35.4 cps.
- ✘ Surface Tension - 28 dynes/cm. (F/L)
- ✘ Shipping Weight - 40 lbs.
- ✘ Packaging: 1.25 gallon containers for easy use
(4 containers per case = 5 gallons)

Part Number: 156-8115

Offense® LV



Physical Properties:

- ✘ Viscosity - 15.3 cps.
- ✘ Surface Tension - 27.8 dynes/cm. (F/L)
- ✘ Shipping Weight - 40 lbs.
- ✘ Packaging: 1.25 gallon containers for easy use
(4 containers per case = 5 gallons)

Part Number: 156-8085

Offense® HV



Physical Properties:

- ✘ Viscosity - 39.1 cps.
- ✘ Surface Tension - 27.3 dynes/cm. (F/L)
- ✘ Shipping Weight - 40 lbs.
- ✘ Packaging: 1.25 gallon containers for easy use
(4 containers per case = 5 gallons)

Part Number: 156-8075



With the Kegel Komfort Program, you will receive an additional 2-year bonus warranty that covers the most expensive parts when you agree to use Kegel chemical products in your new lane machine. *

* Not available with Crossfire Lane Machines

DEFENSE-S®



Physical Properties:

- ✘ Viscosity - 39.6 cps.
- ✘ Surface Tension - 26 dynes/cm. (F/L)
- ✘ Shipping Weight - 40 lbs.
- ✘ Packaging: 1.25 gallon containers for easy use
(4 containers per case = 5 gallons)

Part Number: 156-8025

Cleaners

DEFENSE CX4

Physical Properties:

- ✔ Designed for low-friction surfaces and stronger backend reaction
- ✔ pH: 11.2
- ✔ Shipping Weight - Only 13 lbs.
- ✔ Packaging: 2 liter bottles for easy use
(2 bottles per case = 4 liters)

Part Number: 156-8435



DEFENSE-C

Physical Properties:

- ✔ pH - 12.2
- ✔ Shipping Weight - 48 lbs.
- ✔ Packaging: 2.5 gallon containers
(2 containers per case = 5 gallons)

Part Number: 156-8405



DEFENSE CX4

Physical Properties:

- ✔ Designed for high friction surfaces
- ✔ pH: 11.9
- ✔ Shipping Weight - Only 13 lbs.
- ✔ Packaging: 2 liter bottles for easy use
(2 bottles per case = 4 liters)

Part Number: 156-8425



FIZZION

Physical Properties:

- ✔ pH - 7.8
- ✔ Appearance - White Tablet / Scent - Citrus
- ✔ Tablet Weight - 50 g Shipping Weight: Less than 10 lbs.
- ✔ Packaging: 80 Tablets per Pail

Part Number: 156-8500



AIR TIGHT
PLASTIC SEAL

Note: All Kegel cleaners meet European compliance requirements.

EZ Core Technology makes changing cloth "Quick & EZ"! Stop handling dirty cloth and get ultimate cleaning results.

Physical Properties:

- ✔ Color - White
- ✔ Roll Dimensions - 43" wide x 60' long
- ✔ Shipping Weight - Under 12 lbs.
- ✔ Packaging: 4 rolls per case

Part Number:

K2 Select (Reusable PVC Core) - 153-0047EZ K2 Kloth (Cardboard Core) - 153-0047P



DROP & MOP

Drop & Mop is an all-purpose tablet floor cleaner designed for bowling centers. Its formula was created to leave NO sticky residue so your bowlers' shoes stay clean both on and off the lanes.

- ✔ Mixes up fresh every time you mop for maximum power
- ✔ Cuts through dirt & grease with ease
- ✔ Easily lifts set-in grout stains
- ✔ Includes mild bleaching action
- ✔ Concentrated product reduces waste & pollution
- ✔ Pre-measured tablet controls costs

Part Number: 156-8565



Physical Properties:

- ✔ pH - 7.5
- ✔ Easy to use - spray on, wipe off
- ✔ Gentle on the skin
- ✔ Can be used on all bowling balls
- ✔ Approved for use in USBC competition

Part Number:
156-8768 - 8oz. bottle
156-8768C - Case (12 - 8oz. bottles)
156-8762 - 32oz. bottle



Physical Properties:

- ✔ Keep your hands moisture-free
- ✔ Not sticky - No odor
- ✔ No white powder residue
- ✔ Lasts all day
- ✔ Cleans off with soap and water

Part Number:
156-8773 - 3oz. bottle
156-8773C - Case (10 - 3oz. bottles)



Kustodian Machines

	WALKER SPORT	ION SPORT	ION-B	PLUS
CONDITIONING				
Sanction Technology conditioning system	✓	✓	✓	✓
Conditions each lane in less than 90 seconds	✓	✓	✓	✓
Conditioner float switches with low level warning message	✓	✓	✓	✓
Low maintenance transfer brush conditioning system	✓	✓	✓	✓
Left-Right pattern control	✓	✓	✓	✓
"Oil Only" function	✓	✓	✓	✓
Touchscreen control of microliter stream	✓	✓		
CLEANING				
Sprayless cleaning system	✓	✓	✓	✓
Ability to monitor and adjust cleaner output to the milliliter	✓	✓	✓	✓
Cleaner float switches with low level warning message	✓	✓	✓	✓
Large waste recovery tank (50+ lanes before emptying)	✓	✓	✓	✓
Duster/Cleaning cloth waste roll on top for easy removal	✓	✓	✓	✓
Cushion roller wrap for better cleaning	✓	✓	✓	✓
Super quiet DC vacuum motor	✓	✓	✓	
"Clean Only" function	✓	✓	✓	✓
"Dust Only" function	✓	✓		
Adjustable "End Cleaning" and "Return" distances	✓	✓	✓	✓
Capability to turn pindeck spray on/off	✓	✓	✓	✓
Multi-adjustment squeegee assembly	✓	✓	✓	✓
Touchscreen control of cleaner volume	✓	✓		
DRIVE				
Patented 6 variable drive speeds	✓	✓	✓	✓
Seventh adjustable cleaning speed	✓	✓		
Self-adjusting drive speeds	✓	✓		
Zero Turn Radius lane to lane walking function	✓			
Auto-aligning lane whiskers	✓			
Smart processor auto-align memory	✓			
Object detection	✓			
KEYPAD/PLC				
Standard 2-line display keypad			✓	✓
Full Color 5" touchscreen display	✓	✓		
One program for AM and PM			✓	✓
Three programs for AM and PM	✓	✓		
Automatic burn pair	✓			
Stores 4 programs in memory			✓	✓
Stores 30 programs in memory	✓	✓		
Test outputs	✓	✓	✓	✓
Coded error messages			✓	✓
Full detailed error messages with help	✓	✓		
BATTERIES				
On-board charger			✓	
Separate battery charger	✓	✓		
2 Dry-cell batteries (approx. up to 40 lanes per charge - 400 cycles)		< 32 lanes	< 32 lanes	
2 Dry-cell batteries (approx. up to 60 lanes per charge - 400 cycles)	✓	> 32 lanes	> 32 lanes	
Dual power capabilities (operates with or without power cord)		✓	✓	
Battery Pack (provides up to an extra 20 Lanes)	✓	OPT	OPT	
ACCESSORIES				
KOSI™ software kit included (Kegel Online Support Interface)	✓	✓	✓	✓
Bluetooth® wireless capability (KOSI™ & Connectivity Kit Required)			OPT	OPT

OPT= OPTIONAL

Lane Conditioners

SANCTION TECHNOLOGY

PROPERTIES	NAVIGATE	INFINITY	PRODIGY	DEFENSE-S	OFFENSE HV
VISCOSITY	29.6	35.4	29.7	39.6	39.1
SURFACE TENSION (Force/Length)	26.3 dynes/cm.	28 dynes/cm.	27 dynes/cm.	26 dynes/cm.	27.3 dynes/cm.
PRESSURE & TUBE LENGTH					
50 µL@ 20 LBS	15" tubing	15" tubing	15" tubing	7-3/4" tubing	8" tubing
50 µL@ 15 LBS	10" tubing	11" tubing	10" tubing	4-3/4" tubing	5" tubing
40 µL@ 20 LBS	21" tubing	11" tubing	21" tubing	11-1/4" tubing	12" tubing
40 µL@ 15 LBS	14" tubing	8" tubing	14" tubing	8" tubing	8" tubing
DURABILITY					
High League Lineage	4.5	BEST	3.5	4.5	3
High Open Play Lineage	BEST	3	4.5	3	4
Reduced Pinsetter Calls	4.5	4	BEST	3	4
Easy Cleaning	4	3	4	2	BEST
Limits Carry Down	4.5	4	BEST	4	3
LANE SURFACES					
Pro Lane™	BEST	3	4.5	3	3
Anvilane™	4	BEST	4	4	4
AMF HPL™	4	BEST	4	4.5	4
AMF SPL™	4	BEST	4	4	4
Laneshield®	4	4	4	4	BEST
Guardian®	4	4	4	BEST	4
MAD Lanes®	4.5	BEST	4	4	4
WOOD FINISHES					
Water Base	3	4	3	BEST	3
100% Solids	3	4	3	BEST	4

WICK/PAD TECHNOLOGY

PROPERTIES	NAVIGATE	CROSSFIRE	PRODIGY	OFFENSE LV
VISCOSITY	29.6	23	29.7	15.3
SURFACE TENSION (Force/Length)	26.3 dynes/cm.	28.1 dynes/cm.	27 dynes/cm.	27.8 dynes/cm.
WICKING TIME	13 minutes	10 minutes	14 minutes	8 minutes
DURABILITY				
High League Lineage	BEST	4	3.5	4
High Open Play Lineage	BEST	4	4.5	4
Reduced Pinsetter Calls	4.5	4	BEST	4
Easy Cleaning	4	4.5	4	BEST
Limits Carry Down	4.5	4.5	BEST	3
LANE SURFACES				
Pro Lane™	BEST	4	4.5	3
Anvilane™	4	BEST	4	4
AMF HPL™	4	4	4	BEST
AMF SPL™	3	4	3	BEST
Laneshield®	4	BEST	4	4
Guardian®	4	4	3	BEST
MAD Lanes®	3	BEST	4.5	4
WOOD FINISHES				
Water Base	3	BEST	3	4
100% Solids	3	BEST	3	4

Cleaning



Vacuum Motor - See Motors on page 18
 Following Items are Not Pictured
 Vacuum Housing - 153-0204H
 Fan Blade - 153-0204F
 Flexible Hose (Sold By The Inch) - 154-0260



Universal In-Line Filter Assembly - 154-8867A
 In-Line Filter Assembly - 154-8887 - KP | ION | KW



5" Cleaner Tank Filter - 154-0212B
 1/2" O-Ring - 154-0287C



Cleaner Supply Tank Only - 154-8840 - KK | PX-C | XF
 Complete Cleaner Tank Assembly - 154-8680 - STD | ELT | PXS-C | EP
 Complete Cleaner Tank Assembly - 158-8433C - KW | KP-B | ION-B
 Cleaner Supply Tank Only - 158-8433 - KW | KP-B | ION-B
 Cleaner Supply Tank Only - 154-8894 - KP-A | ION-A
 Expandable Supply Tank Plug (1-1/2") - 153-0246A
 Rubber Insert and Plug for Supply Tank - 153-0247



Recovery Tank - 153-8841 - PXS-A,B | PX-A,B | XF
 Recovery Tank Filter (for tank 153-8841) - 153-8844 - PXS-A,B | PX-A,B | XF

Recovery Tank - 154-8683 - PXS-C | PX-C | KK | KP -A | ELT | STD | ION-A
 Folded Recovery Tank Filter (for tank 154-8683) - 154-8684

Recovery Tank - 158-8434 - KP-B | ION-B
 Recovery Tank - 158-8617 - KW | ION-D
 Recovery Tank Filter (for tanks 158-8434 & 158-8617) - 158-0406
 Recovery Tank Gasket (for tanks 158-8434 & 158-8617) - 158-0405

LEGEND

EP	Elite PLUS	
ELT	Elite	
STD	Standard	
KW	Kustodian Walker	
ION	Kustodian ION	
KP	Kustodian PLUS	
KK	Kustodian	
XF	Crossfire	
PXS	Sanction Machine II Phoenix-S Brunswick Echo	
PX		Phoenix (Firebird)
LW		LaneWalker
LCM	LaneWalker Cleaning Machine	
XL	Excel	
DT	Dart (Breeze)	

Letter suffix indicates model type
 (i.e. Model B).

Parts do not apply to original Sanction Machines

Cleaner Pump Drive Motor
 154-8874 (115VAC)
 154-8875 (230VAC)
 158-8404 (24VDC)
 Peristaltic Cleaner Pump - 154-0860A
 Norprene® Tubing - 154-0861B
 Cleaner Volume Control Valve - 154-1855



Potentiometer
 154-8846 - KP
 158-8413 - ION | KW
 Complete Cleaner Pump Assembly
 154-8859 (115VAC) - KP-A | EP
 154-8859E (230VAC) - KP-A | EP
 Complete Cleaner Pump Assembly
 158-8404C (24VDC) - ION | KW
 154-8847 (24VDC) - KP
 Solenoid Valve (3-Way)
 154-1851 (115VAC) - KP-A Only | EP
 154-1852 (230VAC) - KP-A Only | EP

Tubing Tip
 Kegel recommends you
 change your Norprene®
 tubing at least once
 a year to ensure
 consistent cleaner
 volume.

Kustodian PLUS
 (Model A Only)
 24VDC Cleaner Pump
 Conversion Kit
 154-8844 (115V)
 154-8845 (230V)



Cushion Roller With Cloth Cover - 153-8839

Compatible with XF | KP | EP | ION | KW

Contact Tech Support for use on these models: PX | PXS | KK | STD | ELT

Individual Cloth Cover (Requires 2 covers per roller)

Size A - 154-8889A

Size B - 154-8889B

Size C - 154-8889C

Size D - 154-8889D

Size E - 154-8889E



Cushion Roller - 153-8838 - PX | PXS | KK | STD | ELT

Cushion Roller - 153-8026 - LW

Cushion Roller - 153-8238B - LCM



PVC Take-Up Reel - 153-8824

(Not required with K2 Select EZ Core Cloth)

PVC Take-Up Reel Clamp - 154-6248 (Not Pictured)

Complete Squeegee Assembly (Blue- 45") - 153-0202D

XF | KK | KP | EP | STD | ELT | PXS-C | ION | KW | ION-D | KW-D | LCM

Complete Squeegee Assembly Kit (Brown) - 153-0202A

PX | PXS



Replacement Squeegee Blades - Blue pair - 153-8204E



Replacement Squeegee Blades - Brown pair - 153-8834



Spray Jet Cup Assembly Upgrade

154-8692



Spray Jet Assembly

Tip Retainer - 153-0218

Spray Jet Body - 153-6252

Nylon Body - 153-0217

Spray Jet Cleaner Pumps

Kegel Cleaner Spray Pumps *

158-8212 (115VAC)

158-8213 (230VAC)



* For older Standard AC and SE Machines with Pump Mounted Over Buffer Motor.

154-8651A (115VAC)

154-8652A (230VAC)

Note: This pump replaces SHURflo® & FLOJET® pumps.

Cleaner Pump Repair Kits

Valve/Diaphragm Kit for Kegel Pump - 158-8212K

Cleaner Tip & Hose - 154-8852 - KP | EP | ION | KW

Screen Check Valve - 153-0220

Outside Spray Tip (1501) - 154-0007

Inside Spray Tip (8003) - 153-0207

Inside Spray Tip (11003) - 153-0207A

Cleaner Tip Check Valve (Pkg of 5)

154-0862K - KP | EP | ION | KW

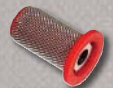

Cleaner Funnels

Cleaner Funnel - Long Stem
158-8252

Cleaner Funnel - Short Stem
154-8647

Cleaner Funnel - No Stem
153-0252

Conditioning



Conditioner Transfer System

Conditioner Transfer Brush Assembly - 154-0866 - KP | EP | ION | KW

Buffer Brush - 154-8641 - STD | ELT | PXS-C | KK | KP | PX-C | EP | ION | XF | KW

Buffer Brush - 153-8407 - PXS-A,B | PX-A,B | XL | DT

Buffer Brush - 153-8017 - LW

Transfer Roller - 153-8408 - PX-A,B | XL | DT

Transfer Roller - 154-8338 - PX-C

Transfer Roller (2.25 diameter) - 154-8207 - PXS-A,B

Transfer Roller (1.75 diameter) - 154-8208 - PXS-A,B

Transfer Roller - 154-8608 - KK | ELT | PXS-C | STD

Transfer Roller - 158-8204 - XF

Buffer Belt - 154-9615 - STD | ELT | KK | KP | PXS-C | EP | ION A-B

Buffer Belt - 153-9015 - PXS-A,B | PX-A,B | LW

Buffer Belt - 153-9817 - PX-C

Buffer Belt - 158-9201 - XF

Buffer Belt - 158-9026 - KW | ION-D

Head Drive Belt - 154-9201 Compatible with all applications.

Wicks



Glueless Wick Plate Assembly

3" - 153-8103A Replacement for glued wicks
3.125" - 153-8123 Only Compatible with PX-C
3.125" - 158-8223 Only Compatible with XF



5" - 153-8105A Replacement for glued wicks
5.125" - 153-8125 Only Compatible with PX-C
5.125" - 158-8225 Only Compatible with XF



7" - 153-8107A Replacement for glued wicks
7.125" - 153-8127 Only Compatible with PX-C
7.125" - 158-8227 Only Compatible with XF

10" - 153-8110A Replacement for glued wicks
10.125" - 158-8230 Only compatible with XF

Not Pictured

45" Felt Material for Glued Wicks - 153-0005 (4")
45" Felt Material for No-Glue Wicks - 153-0005B (5")
Felt Material Stock for No-Glue Wicks - 153-0005D
 (Custom cut to be purchased by the inch)



Wick Spring (0.438 OD x 2.75) - 153-2095
Wick Spring (XF Only) - 153-2740

Pattern Smoothing Pads



Pattern Smoothing Assembly - 154-8617



Velcro for Smoothing Pad
 154-8617V (10 per pack)



Smoothing Pad Spring
 153-2540A

1. Pulse Suppression Assembly

154-8660 - ELT | PXS-C | STD | EP

154-8216K - PXS-A,B

154-8816 - KK | KP | ION | KW

2. Pressure Gauge (60 psi) - 158-1613 (Replaces 154-1225)

3. Oil Control Valve (24VDC) - 154-1209

Not Pictured

Calibration Valve (115VAC) - 154-1210 - PXS-A,B

4. Vent Valve - 154-8817 (Electrical Vent Valve Discontinued)

5. Oil Tank Assembly with Fittings/Float

154-8682 - ELT | STD | PXS-C | KW | KP | EP | ION

Oil Tank Assembly with Fittings

154-8842 - KK

6. Oil Tank Filter - 154-0212

7. Float Switch Assembly

154-1203 - XF

154-1617 - ELT | PX-C | PXS-C | KP | EP | ION | KW

154-8203 - PXS-A, B (3" Vertical for tank 154-8201C)

154-8203A - STD | ELT (7" Vertical for tank 154-8615C)

8. Belt for Conditioner Pump Motor

154-9202A (60Hz)

154-9215 (50Hz)

9. Elbow 3/8" Tube x 1/4" NPT - 154-0225

Fluid Metering Components

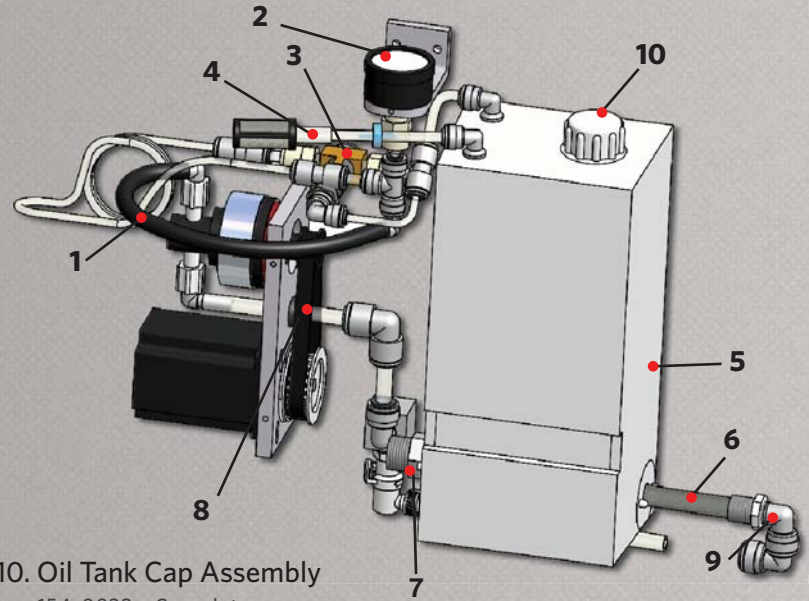

10. Oil Tank Cap Assembly

154-0832 - Complete

154-0832C - Cap only

154-0832G - Gasket only

Miscellaneous

Conditioner Head Tip & Hose Holder Assembly (includes tubing)

1- 1/4" Tip Holder (PXS only) - 154-8285

3- 1/2" Tip Holder (Painted Machines with Transfer Roller) - 154-8883

4- 1/2" Tip Holder (Painted Machines with Transfer Brush) - 154-8851

5- 1/4" Tip Holder (Upgraded Transfer Brush Models) - 154-8896

Retaining Spring for Head - 153-2713

Graduated Cylinder (25ml) - 154-0215

Felt for Graduated Cylinder (25ml) - 154-0210

Graduated Cylinder (50ml) - 154-0215A

Felt for Graduated Cylinder (50ml) - 154-0210A

Oil Funnel with 3" Hose - 153-0052A

Funnel with Connecting Stem for Conditioner Tank (Small) - 154-8648

Oil Pencil Tip (Molded) - 154-6832

Replacement Felt

Felt (1/8" x 3") - 154-0228S - Sold by the inch.

Felt Strip on Splash Guard Tank - 154-8333 - PX-C Only

Felt Kit for Transfer and Spray Jet Wall - 154-8669 - PXS-C | STD | KK | ELT

Felt for LDS Splash Guard - 154-8690 - All painted Sanction Technology Machines

Felt Strip for Transfer Wall - 154-8669A - KP | EP | ION | KW

FMI® Oil Pump - 154-1214

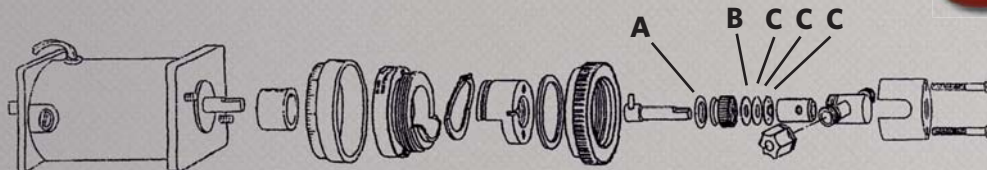

A. O-Ring for Fluid Metering Pump (Orange) - 154-1214E

B. Gland Seal for Fluid Metering Pump (White) - 154-1214D

C. Lip Seal for Fluid Metering Pump (Red) - 154-1214A

PLC & Batteries

Programmable Logic Controllers (PLC)

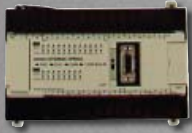

CPM2A PLC

154-1801 (115VAC / 230VAC)
158-1423 (24VDC)

Not Pictured

154-1801M - PX-C EXPANSION MODULE

Omron® PLC Battery

153-1001C - C28H | C200H
154-1804 - CPM2A

Keypad

154-8806 - KK | KP | ION
154-8807 - PX-C
154-8809 - Firebird

Keypad Overlay Decal

154-0801 - KK | KP | ION
154-0251 - PXS, ELT, STD
158-0204 - XF
153-0844 - PX-C
153-0844F - Firebird
158-0802 - KW-B
153-0801 - PX
153-0025 - LW, LCM

Keypad Cable - 154-1803

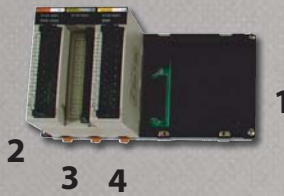

C200HS Items

1. Mounting Rack C200H - 153-1811
2. Input Module ID212 - 153-1816
3. Output Module OC221 - 153-1814
4. Output Module OC222 - 153-1815

Not Pictured

Keypad with Cable - 153-1002C

PLCs No Longer Available:

SP-16 PLC
C28H PLC
C200HS PLC

Call 863-734-0200 for more information.



Sport Edition PLCs

CP1HX PLC - 158-1610P
Touchscreen Display - 158-8671
Converter for CP1 - 158-1610C
Communication Cable - 158-1610CC
Touchscreen Protector - 158-1612

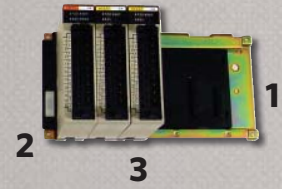

C200HG Items

1. Mounting Rack C200HW - 154-1201B
2. Input Module ID212 - 153-1816
3. Output Module OC222 - 154-8231
(With 24VDC Relay)



C200HG PLC
154-1201



Power Supply
C200HG - 154-1201P

TWIDO® PLCs (Crossfire Only)

Programmable Logic Controller

Please contact KEGEL for correct part number.

Real Time Clock - 158-1201C

Connector (RS485 Mini-DIN) - 158-1201D

Output Module - 158-1202

Keypad Cable - 158-1203C

Keypad Assembly - 158-8209

TWIDO® PLC Battery - 155-1246



Replacement Batteries & Chargers

Odyssey® PC925 Batteries

(Sold in Pairs)- 158-8651

Odyssey® PC1200 Batteries

(Sport Edition - Sold in Pairs)

158-8652

DC Voltage Regulator - 158-8417

Smart Charger (IQ-4) - 158-1452 for ION

Battery Charger Assembly

Please contact Kegel for exact part number for your machine model.



Battery Packs

Battery Pack for Sport Edition

158-8631

Battery Pack Upgrade for ION-B & KW-B

158-8635

External Charger Conversion Kit ION-D

(Serial numbers prior to IC-17944)

158-8670 (115V)

158-8670E (230V)

Odyssey® PC680 Batteries

(Sold in Pairs)- 158-8650

NOTE: Battery voltage must be closely matched on both batteries for best performance. Please contact Kegel for Conversion Kit from Valence® to Odyssey® Batteries.

Electrical Components

Omron® Brand Relays

LY2 Relay - 153-1016D (24VDC Coil)
 LY2 Relay - 153-1016 (115V) 153-1616 (230V)
 LY3 Relay - 153-1018 (115V) 153-1618 (230V)
 LY4 Relay - 153-1406 (115V) 154-1611 (230V)
 PLC Output Relay - 153-1032
 PLC Output Relay - 154-1215 (24VDC Coil)

Phoenix® Brand Relays

MY4 Relay (24VDC) - 158-1427
 Secondary Relay Assembly (24VDC)
 154-1835 - KK | KP

Automation Direct® Relays

2 Pole (15A - 24VDC) - 158-1413
 2 Pole (10A - 24VDC) - 158-1420G

Relays for Sport Edition

24VDC DPDT - 158-1458
 Solid State - 158-1460
 DPDT 10A - 158-1462
 Super MY4 24VDC - 158-1463

Other Electrical Components

Duster Switch (Large) - 154-1603 - ELT | PXS-C | KK | KP | PX-C | EP | ION | KW
 Duster Switch (Small) - 153-1202 - for PXS-A,B | PX-A,B | XF
 Brush Switch - 153-1203 - for All Machines
 Squeegee Switch (Small) - 153-1203 - PXS-A,B | KP | PX-A,B | EP | XF | ION
 Squeegee Switch (Large) - 154-1015 - STD | ELT | PXS-C | KK | PX-C

Pass-Through Sensor - 153-1031A
 Sensor Plug and Cable - 153-1031B
 Proximity Sensor - 154-1220
 Proximity Sensor (XF-A) - 158-1208

Solenoid (115V) - 153-1027
 Solenoid (220V) - 153-1627
 Solenoid Cable Assembly 7.625" - 153-8812 (PX-A,B)
 Solenoid Cable Assembly 8.25" - 153-8812A (PX-C)

LCD Amp Gauge Assembly - 158-8410 ION | KW
 Red Push Button (Normally Open) - 153-1408
 Horsepower Resistor 0.025 Ω - 153-1015A
 Horsepower Resistor 0.050 Ω - 153-1015
 Arc Suppressor - 158-1438
 Contactor - 158-1465
 (Used for Sport Edition Vacuum & Auto Shutdown Relay)

Head Motor 6.0μF Capacitor
 154-1208 - PXS | KK | KP | STD | ELT | EP

Oil Pump Motor 1.5μF Capacitor
 154-1208B - PXS | KK | KP | STD | ELT | EP



Fuses & Breakers

Panel Mount Fuse Holder (115V) - 153-1028
 Fuse 0.5A (UL) - 154-1261
 Fuse 0.75A (UL) - 154-1262
 Fuse 1.8A (UL) - 154-1265
 Fuse 2.25A (UL) - 154-1266
 Fuse 3.2A (UL) - 154-1267
 Fuse 4A (UL) - 154-1268C
 Fuse 7.5A (UL) - 154-1270
 Fuse 8A (UL) - 154-1270C
 Fuse 10A (UL) - 154-1273
 Fuse 20A (UL) - 154-1274C

Panel Mount Fuse Holder (230V) - 153-1028E
 Fuse 315mA (IEC - 230V) - 154-1260E
 Fuse 1A (IEC - 230V) - 154-1264E
 Fuse 1.6A (IEC - 230V) - 154-1265E
 Fuse 4A (IEC - 230V) - 154-1267E
 Fuse 6.3A (IEC - 230V) - 154-1269C

Circuit Breaker 8A - 153-1810
 Circuit Breaker 10A - 153-1030
 Rocker Breaker 15A - 154-1610
 Circuit Breaker 20A (24VDC) - 158-1451
 Rocker Breaker 10A - 154-1272

Breaker for E-Stop (Prior to 2008) - 154-1251
 Breaker for E-Stop (2008 and later) - 154-1251A
 2008 E-Stop - 154-1250A
 (2-Hole Pattern)



Blade Type Fuses

Fuse 25A - 158-1439 for Voltage Regulator - ION | KW
 Fuse 40A - 158-1440 for IOTA® Battery Chargers
 Maxi-Fuse 40A (for Fuse Link) - 158-1454 for ION
 Fuse Link Assembly - 158-8421

Power Cord Components

Description	115VAC	230VAC
Power Cord PX A-B	153-8810	153-8811A
Power Cord PXS A-B	154-8229A	154-8230
Power Cord STD ELT PXS-C EP	154-8629	154-8630
Power Cord KK KP ION XF PX-C	154-8829	154-8830
Male Plug End (15A)	153-1025	153-1625
Male Plug End (20A)	153-1825	N/A
Female Twistlock Plug (15A)	153-1024	153-1624
Female Twistlock Plug (20A)	153-1822	153-1824
25' Charging Cord Assembly ION A-B KW	158-8425	158-8425E
Velcro Strap For Cord	154-0242	154-0242

Upgrades

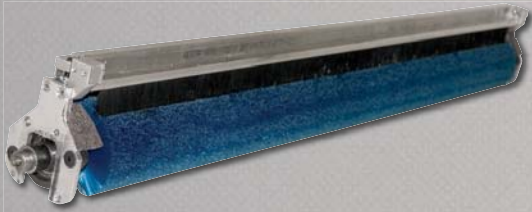

Conditioner Transfer System Upgrade (1 piece)

158-8430 - Compatible with: PXS-C | KK | STD | ELT | KP-A | ION-A

Conditioner Transfer System Upgrade (2 piece to 1 piece)

158-8430C - Compatible with: PXS-C | KK | STD | ELT | KP-A | ION-A

Upgrades for Crossfire

Complete Upgrade - Includes 8 Wicks with Cam

Roller and Large Conditioner Supply Tank

158-8241 (115V) | 158-8241E (230V)

Conditioner Tank Upgrade

158-8215 (115V) | 158-8215E (230V)

8 Pad Wick & Cam Kit - 158-8214

Proximity Upgrades



Lane Distance Sensor (LDS) Upgrade with Proximity Sensor

LDS (Right) PXS-A,B 154-8291

LDS (Center) PXS-A,B 154-8292

LDS (Center) STD 154-8672

Tach (Internal) PXS-A,B 154-8289

Tach (External) PXS-A,B | STD 154-8290

Head Timing STD | PXS-A,B 154-8673

Kustodian Proximity and Relay Upgrades

Kustodian Model A to C Upgrade Kit - 154-8870

Serial Number: KK-0600 through KK-0810

Kustodian Model B to C Upgrade Kit - 154-8871

Serial Number: KK-0811 through KK-0987

Spray Jet Cup Assembly Upgrade See page 9.

Oil Tank Upgrade Kit for Phoenix-S Models A & B

Move the Oil Pump to the "TOP" of your priorities!

With the wide variety of conditioning programs and pump settings, this "must have" upgrade moves the oil pump to the top side of the machine, allowing the operator to change the microliter per board setting without the hassle of lifting the machine. Best of all, the new durable plastic molded tank is "see through" so it is easy to check the oil level and perform preventive maintenance.



Oil Tank Upgrade Kit for PXS-A,B - 154-8841

Push Button Replacements

Handle Wire without Connector - 153-8424A

Handle Wire with Kill Plugs PXS-A,B | PX-A,B - 153-8424C

Handle Wire for ION | KP - 154-8893B

Handle Wire for PXS-C | STD | ELT - 154-8624



Handle Reinforcement Kit
154-8284



Spray Pressure Regulator Upgrade - 154-8268

Transport Caster Upgrade - 154-8281

KOSI PRO Software Kegel Online Support Interface

For All Sanction Technology Lane Machines! Quick and Easy to Use.

KOSI PRO & CABLE (7.x) - 154-8771

KOSI PRO, CONVERTER & CABLE (7.x) - 154-8771A

KOSI PRO UPDATE (7.x) - 154-8771U

KOSI PRO UPGRADE (5.x/6.x to 7.x) - 154-8771C

Data Cables

KOSI Serial to Serial Port Cable - 154-8724

RS232 Converter Module for KOSI Cable

(for Omron® C200HG & C200HS) - 154-1614

USB to Serial Port Converter & KOSI Cable - 154-8771B

LDS Shaft Assembly

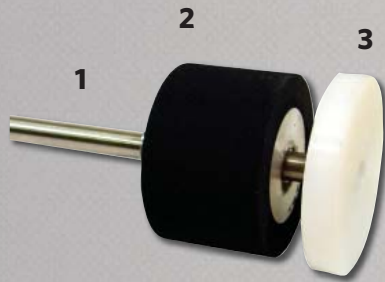

1. Shaft - See Operators Manual
2. Wheel - 153-7002AA
3. Kick Up Wheel - 153-7401

Momentary Wheel Assembly



- Wheel - 153-7005R
 Shaft - 153-6006
 Housing - 153-6029

Transport Wheels



- Lane to Lane Caster 2"
 153-0812 (Heavy Duty)
 Transport Caster
 3" Dual Wheel - 153-0001
 2" Single Wheel - 153-0002

Tune Up Kits



- PX-B (115V) - 153-8888
 PXS-A,B (115V) - 154-8288
 KP | EP (115V) - 154-8686
 KP | EP (230V) - 154-8687
 STD (115V) - 154-8688
 KK | ELT | PX-C | PXS-C (115V) - 154-8888
 ION - 158-8428
 KW - 158-8628

Spare Parts Kit



Call for part number



- Walker Whisker
 Spring - 153-2946
 Black Vinyl Cap - 153-2941
 Complete Assembly - 158-8623

Guide Rollers



- Guide Roller - 153-8410
 Not used on LW | LCM | ION-D | KW-D
- Guide Roller - 153-8310 - LW | LCM
 Guide Roller Shoulder Bolt - 153-2407
 Guide Roller Mounting Bar - 153-6417
 Guide Roller Spring - 153-2401
 SHCS 1/4-20 x 2-3/4 - 153-2211

Lid Components



- Push Latch with Key - 154-0881
 Flush Mount Lid Latch (without lock) - 153-2232A
 Flush Mount Lid Latch (with lock) - 153-2232L
 Middle Slide Latch - 154-0005
 Straight Quarter-turn Lid Latch (with slot) - 154-0804
 Flange Quarter-turn Lid Latch (with slot) - 154-0805
 Bent Catch Quarter-turn Lid Latch (with slot) - 154-0819
- Rubber Bumper - 154-0006A
 Foam (sold by inch) - 153-0036

Adjustable Guide Rollers

Introduced on the Model D ION and Model D Walker



- Complete Front Assembly - 158-8643
 Front Wheel Only - 158-8637
 Complete Rear Assembly - 158-8642
 Rear Wheel Only - 158-8636
 Compression Spring - 153-2978

Miscellaneous

Fittings



Elbow
1/4 Tube x 1/4 Tube - 154-0243



Elbow
3/8 x 3/8 - 154-0256



Elbows
3/8 NPT x 1/4 Tube - 154-0412
3/8 NPT x 3/8 Tube - 154-0803



Elbows
3/8 Tube x 1/4 NPT - 154-0225
1/4 Tube x 1/4 NPT - 154-0223



Elbow
1/4 Stem x 1/4 Hose Barb
154-0226



Elbow
1/4 Stem to 5/16 Hose Barb
154-0227



Elbow
3/8 Stem to 5/16 Hose Barb
154-0239



Elbows
3/8 Stem x 3/8 Tube - 154-0258
3/8 Stem x 1/4 Tube - 158-1214



Elbow
1/4 Stem x 1/4 Tube - 154-0222



Elbow
1/8 NPT x 3/16 Tube - 154-0613



Male Swivel Elbow
1/4 Tube x 1/4 NPT - 153-0818



Compression Fitting
1/4 x 3/8 MPT - 153-0212



Reducing Union
1/4 x 3/16 - 154-0248



Bulkhead Union
3/8 x 3/8 - 154-0285



Union
1/4 x 1/4 154-0241



Union Tee
1/4 Tube - 153-0815



Reducing Union
3/8 to 1/4 - 154-0244



Male Connector
1/4 Tube x 1/8 NPT - 154-0224



Female Connector
1/4 Tube x 1/8 FPT - 154-0257



Union Tee
3/8 Tube - 154-0815



Male Connectors
1/2 Tube x 1/2 NPT (Drilled)
154-0232D
1/4 x 1/4 MPT - 153-0209



In-line Coupler
1/8" - 154-0230



Stem Adapter
1/4 NPT x 1/4 Stem - 154-0243S



Male Luer
1/8 Hose Barb -154-0863



Tank Plugs
1/4" - 154-0245
3/8" - 153-1054
1/2" - 154-0231



O-Rings for Fittings
1/4" - 154-0287A
3/8" - 154-0287B
1/2" - 154-0287C



Oil Fill Stem - PX
3/8 x 3/8 - 153-1055

Tube Stock Chart



All Tubing Sold By The Inch
Cleaning

- 1/4" - 153-0208S
- #24 Norprene® - 154-0861



Conditioning

- 3/16" - 154-0202B
- 1/4" - 154-0202A
- 3/8" - 154-0202
- 3/8" Viton® - 154-0201A







HEX HEAD CAP SCREWS

					
1/4		5/16		3/8	
7/8"	153-2052	1"	153-2061	1"	153-2066
1"	153-2053	1/4"	153-2062	1 1/4"	153-2067
1 1/4"	153-2054			1 1/2"	153-5068
1 1/2"	153-2055			2"	153-2069







MACHINE SCREWS PHILLIPS

					
# 6		# 8		# 10	
1/2"	153-2081	5/8"	153-2086	3/4"	153-2091
7/8"	153-2083	3/8"	153-2086A	1"	153-2092
1"	153-2084	3/4"	153-2087		
1 1/4"	153-2085	1"	153-2089		
		1 1/2"	153-2090		

HEX NUTS

		STANDARD	NYLOK	JAM
	#6		153-2018	
	#8		153-2019	
	#10	153-2022	153-2208	153-2524
	1/4	153-2023	153-2020	153-2304
	5/16	153-2024	153-2735	5/16-18 153-2027A 5/16-24 153-2214
	3/8	153-2025	153-2021	153-2027
	1/2	153-2026		

WASHERS

		FLAT	LOCK
	#6	153-2001	
	#8	153-2002	
	#10	153-2003	153-2013
	1/4	153-2004	153-2014
	5/16	153-2005	153-2015
	3/8	153-2006	153-2016

MOLEX PLUGS

		
CONNECTOR	MALE	FEMALE
2 PIN	153-1041	153-1042
3 PIN	153-1044	153-1043
5 PIN	158-1206	158-1207
6 PIN	154-1231	154-1232
9 PIN	153-1039A	153-1040
12 PIN	153-1602A	153-1603
15 PIN	154-1807	154-1808
PINS	153-1046	153-1045
Pin Removal Tool		153-4002

WIRE CLAMPS

1/8	153-1049D
1/4	153-1049A
3/8	153-1049E
1/2	153-1049B
3/4	153-1049C



Motors & Speed Controls

COMPONENTS	PXS-A,B	PXS-C STD AC	KK KP	KW ION-A,B	KW-D ION-D	STD SE ELT EP
Blower Motor (115VAC)	153-8801	N/A	N/A	N/A	N/A	N/A
Blower Motor (230VAC)	153-8802	N/A	N/A	N/A	N/A	N/A
Buffer Motor (115VAC)	153-8016A	154-8616A	154-8616A	N/A	N/A	154-8616B
Buffer Motor (230VAC)	153-8616	154-8616E	154-8616E	N/A	N/A	154-8616E
Buffer Motor (24VDC)	N/A	N/A	N/A	158-8414	158-8414	N/A
Buffer Motor Brushes	N/A	N/A	N/A	158-1406B	158-1406B	N/A
Buffer Motor Contactor (115VAC)	153-1004	153-1004A	153-1004A	N/A	N/A	153-1004A
Buffer Motor Contactor (230VAC)	153-1604	153-1604A	153-1604A	N/A	N/A	153-1604A
Circuit Board w/Speed Relays (115VAC)	154-8210	154-8312	154-8810	N/A	N/A	N/A
Circuit Board w/Speed Relays (230VAC)	154-8210	154-8644	154-8811	N/A	N/A	N/A
Circuit Board w/Speed Relays (24VDC)	N/A	N/A	N/A	158-8409	158-8409	N/A
Conditioner Pump Motor (115VAC)	154-8234	154-8604	154-8604	N/A	N/A	154-8604
Conditioner Pump Motor (230VAC)	154-8234	154-8604E	154-8604E	N/A	N/A	154-8604E
Conditioner Pump Motor (24VDC)	N/A	N/A	N/A	158-8401A	158-8632	N/A
Cond. Pump Motor Brushes (24VDC) BISON	N/A	N/A	N/A	158-1422B	158-1422B	N/A
Cond. Pump Motor Brushes (24VDC) GROSCHOPP	N/A	N/A	N/A	158-1422G	158-1422G	N/A
Drive Motor (90VDC)	153-8065	153-8065 - STD	154-8865	N/A	N/A	153-8065 - STD
Drive Motor (90VDC)	N/A	154-8365 - PXS-C	N/A	N/A	N/A	154-8365 - ELT EP
Drive Motor (24VDC)	N/A	N/A	N/A	158-8406 - ION	N/A	N/A
Drive Motor (24VDC) Long Shaft	N/A	N/A	N/A	158-8602 - KW	158-8602	N/A
Duster Motor (115VAC)	153-8403	153-8403	153-8403	N/A	N/A	153-8403
Duster Motor (230VAC)	153-8803H	153-8803H	153-8803H	N/A	N/A	153-8803H
Duster Motor (24VDC)	N/A	N/A	N/A	158-8403	158-8403	N/A
Head Drive Motor (115VAC)	154-8232	154-8232	154-8232	N/A	N/A	154-8232
Head Drive Motor (230VAC)	154-8232	154-8632	154-8632	N/A	N/A	154-8632
Head Drive Motor (24VDC)	N/A	N/A	N/A	158-8405	158-8632	N/A
Head Drive Motor Brushes (24VDC)	N/A	N/A	N/A	158-1404B	N/A	N/A
Isolator Analog Card 115VAC Drive Assembly	N/A	N/A	N/A	N/A	N/A	154-8633
Isolator Analog Card 230VAC Drive Assembly	N/A	N/A	N/A	N/A	N/A	154-8634
Isolator Analog Card 115VAC Buffer Assembly	N/A	N/A	N/A	N/A	N/A	154-8635
Isolator Analog Card 230VAC Buffer Assembly	N/A	N/A	N/A	N/A	N/A	154-8636
Isolator Analog Card Only	N/A	N/A	N/A	N/A	N/A	154-1413
Speed Control Assembly (24VDC-Drive)	N/A	N/A	N/A	158-8412	158-8412	N/A
Speed Control Assembly (24VDC-Cleaner Pump)	N/A	N/A	154-8848	158-8415	158-8415	N/A
Speed Control Assembly (Oil/Cleaner Head)	N/A	N/A	N/A	N/A	158-1605	N/A
Speed Control Board Only (115VAC)	153-1012	153-1012	153-1012	N/A	N/A	153-1012
Speed Control Board Only (230VAC)	153-1812	153-1812	153-1812	N/A	N/A	153-1812
Speed Control Board Only (24VDC)	N/A	N/A	N/A	158-1410	158-1410	N/A
Squeegee & Brush Lift Motor (115VAC)	153-8207	153-8207	153-8207	N/A	N/A	153-8207
Squeegee & Brush Lift Motor (230VAC)	153-8807H	153-8807H	153-8807H	N/A	N/A	153-8807H
Squeegee & Brush Lift Motor (24VDC)	N/A	N/A	N/A	158-8402	158-8402	N/A
Transfer Roller Motor (115VAC)	154-8206	154-8206	154-8206	N/A	N/A	154-8206*
Transfer Roller Motor (230VAC)	154-8206A	154-8206A	154-8206A	N/A	N/A	154-8206A*
Vacuum Motor (115VAC)	153-8205	154-8805	154-8805	N/A	N/A	154-8805
Vacuum Motor Brushes (115VAC Pair)	153-0204B	153-0204B	153-0204B	N/A	N/A	153-0204B
Vacuum Motor (230VAC)	153-8805	154-8805E	154-8805E	N/A	N/A	154-8805E
Vacuum Motor Brushes (230VAC Pair)	153-0204C	153-0204C	153-0204C	N/A	N/A	153-0204C
Vacuum Motor (24VDC)	N/A	N/A	N/A	158-8407	158-8407	N/A
Vacuum Brushes (24VDC)	N/A	N/A	N/A	158-1421B	158-1421B	N/A

* Not used on Kustodian PLUS or Elite PLUS

COMPONENTS	PX - A,B	PX - C	XF
Blower Motor (115VAC)	153-8801	N/A	N/A
Blower Motor (230VAC)	153-8802	N/A	N/A
Buffer Motor (115VAC)	153-8016A	154-8616A	154-8616A
Buffer Motor (230VAC)	153-8616	154-8616E	154-8616E
Buffer Motor Contactor (115VAC)	153-1004	153-1004A	153-1004A
Buffer Motor Contactor (230VAC)	153-1604	153-1604A	153-1604A
Circuit Board w/Speed Relays (115VAC)	N/A	154-8330	N/A
Circuit Board w/Speed Relays (230VAC)	N/A	154-8331	N/A
Drive Motor (90VDC)	153-8065	154-8865	154-8865
Duster Motor (115VAC)	153-8403	153-8403	153-8403
Duster Motor (230VAC)	153-8803H	153-8803H	153-8803 H
Speed Control Assembly (115VAC 3-Speed)	153-8822	N/A	N/A
Speed Control Assembly (230VAC 3-Speed)	153-8823	N/A	N/A
Speed Control Assembly (115VAC 4 Speed)	153-8842	N/A	N/A
Speed Control Assembly (230VAC 4 Speed)	153-8843	N/A	N/A
Speed Control Assembly (115/230VAC 3-Speed)	N/A	N/A	158-8211
Speed Control Board Only (115VAC)	153-1012	153-1012	158-1212R
Speed Control Board Only (230VAC)	153-1812	153-1812	158-1212R
Squeegee & Brush Lift Motor (115VAC)	153-8207	153-8207	153-8207
Squeegee & Brush Lift Motor (230VAC)	153-8807H	153-8807H	153-8807
Transfer Roller Motor (115VAC)	153-8828	154-8332	153-8828
Transfer Roller Motor (230VAC)	153-8829	154-8332E	153-8829
Vacuum Motor (115VAC)	153-8205	154-8805	158-8208
Vacuum Motor Brushes (115VAC Pair)	153-0204B	153-0204B	153-0204B
Vacuum Motor (230VAC)	153-8805	154-8805E	158-8208E
Vacuum Motor Brushes (230VAC Pair)	153-0204C	153-0204C	153-0204C

For Dayton® Drive Motor - 153-8065

Rear Seal - 153-1057R
Gasket - 153-1057F
Front Seal - 153-1057S
Drive Motor Brushes (90VDC Pair) - 153-1057H

For All Baldor® Drive Motors

Drive End Rear Seal - 154-1809D
Housing End Front Seal - 154-1809E
Drive Motor Brushes (24VDC Pair) - 158-1405B
Drive Motor Brushes (90VDC Pair) - 154-1809B

NPS™ (NO PIN SLIDE)



NPS (No Pin Slide) creates a textured surface which helps the pins grip and fall down rather than slide out of range. Apply it to the pin deck and the problem is solved.

Physical Properties:

- ✘ Weight per container - 9 lbs.
- ✘ Shipping Weight - 40 lbs.
- ✘ Packaging: 1 gallon bottle for easy use (4 gallons per case)
- ✘ Concentrated Solution

Part Number: K-99C



Properties:

- ✘ Cleans ALL types of bowling pins
- ✘ Includes attachment to sand pins
- ✘ Weight: 37 pounds

Part Number:

17-0040 - 115V 60 Hz

17-0040E - 230V 50 Hz



Properties:

- ✘ Cleans ALL types of bowling pins
- ✘ Not harmful to skin
- ✘ For use in ALL pin cleaning machines
- ✘ Weight: 1 gallon is approximately 8.7 pounds
- ✘ Packaging: 1 gallon bottle/box
- ✘ Concentrated cleaner
- ✘ pH: 8.75

Part Number: 156-8800



Toll Free (US Only): 800 - 280 - BOWL (2695)

Fax: 863 - 734 - 0204

International: +1 - 863 - 734 - 0200

www.kegel.net

1951 Longleaf Boulevard
Lake Wales, FL 33859 USA



YOUR LANES | OUR PASSION